



INNOVATIVE BUILDING PRODUCTS™
an **ACME BRICK** company

Claddings





<https://innovativebuildingproducts.com/fast-track>

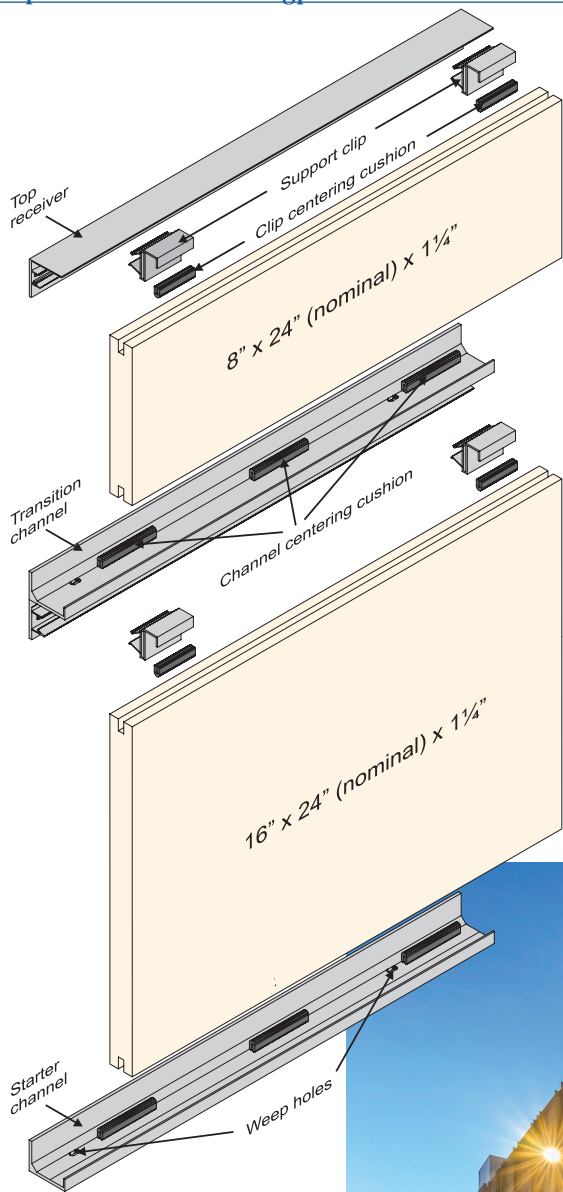

Solutions-based system that is engineered for challenging places to clad, like soffits and angled walls.



Take it inside. Thinner stone allows for interior applications and keeps the load on the wall lighter.



System allows for quick installation, easy replacement, and recladding opportunities. Use with any kerfed cladding panels.

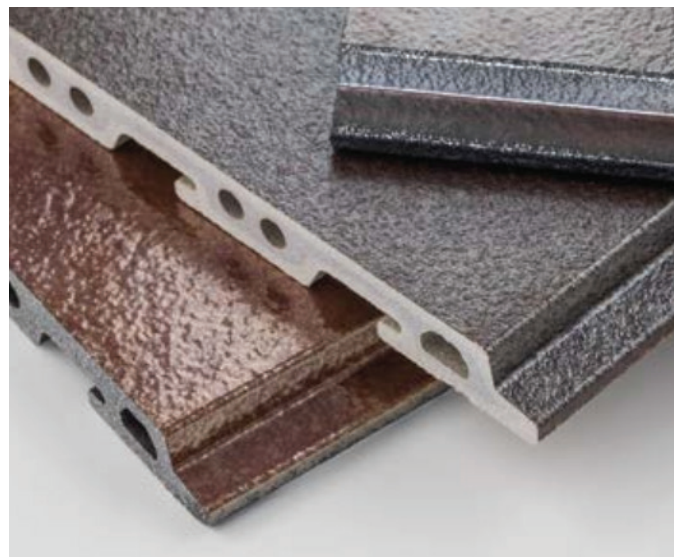

Matte, silky-matte or glossy as well as various three-dimensional cross-sections. More than 50 colors and numerous material looks and metallic glazes.



KeraShape® is available as rectangular oval tubes with three or four glazed sides in 3 different cross-sections and lengths of up to 180 cm.



Hytect Technology allows the facade to be self-washing. Titanium dioxide is baked onto every ceramic surface at high temperatures: it decomposes microorganisms and removes air pollutants, leaving the facade maintenance free for the life cycle of the building.

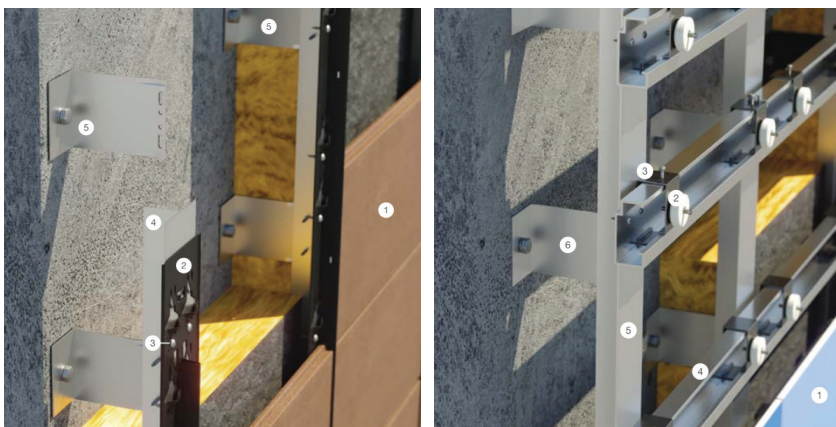

KeraTwin® K20 facade panels are hung in the vertical system rail. More engineered systems available and varies by the panel coursing.



KeraAion® is the large format product line hung with visible clamps. Panels can be produced up to 4' x 4'.



<https://innovativebuildingproducts.com/mac>

Various profiles including Harrywood PLUS (shown below), Norwood, Norwood mini, and new board and batten.



WOOD COLLECTION



SIGNATURE COLLECTION



INSPIRATION COLLECTION

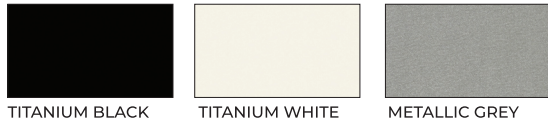

MAC Metal Architectural steel products will never require maintenance or warp, and comes with a 40-year no fade warranty.



MAC's unique painting process offers superior protection against inclement or extreme weather conditions. It is 2x more resistant to UV rays, and 3x more resistant to corrosion, fading, and scratching than competing products.



Choose cladding with peace of mind. MAC ensures its longevity and robustness with its 40-year quiet guarantee.

CUPACLAD

Developed with the support of Danish architects and installers, the CUPACLAD® systems revolutionize the traditional natural slate façade installation methods.



CUPACLAD black slate is a sustainable and competitive solution that uses high durability tectonic natural slates, new fixing systems, and takes full advantage of the efficiency of ventilated façades. Order a free sample today.

<https://innovativebuildingproducts.com/cupa-clad>

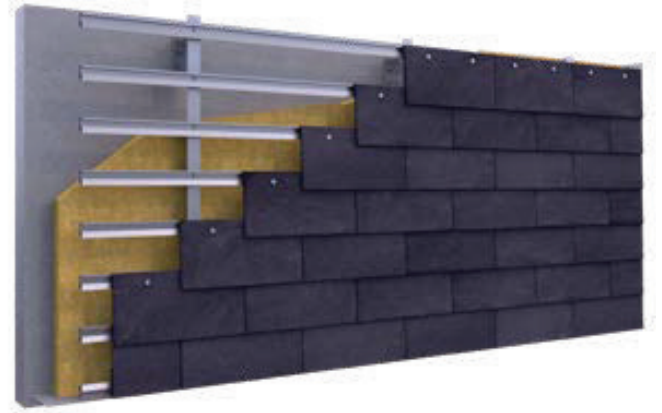

CUPACLAD Black



This library takes advantage of the CUPACLAD system to provide a durable, sustainable, and easy-to-install slate cladding with unique character.



These cladding systems adapt natural slate to new architectural trends and styles that demand a more sustainable approach.

PURA[®] NFC

BY TRESPA



<https://innovativebuildingproducts.com/pura-nfc>

Pura[®] NFC is made of up to 70% natural fibers that go through an advanced in-house manufacturing process.



Romantic Walnut



Aged Ash



Slate Ebony



Mystic Cedar



Siberian Larch

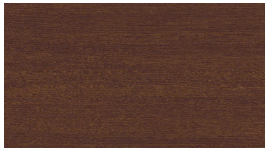

Tropical Ipe



Classic Oak



Western Red Cedar



French Walnut

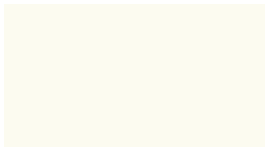

Athens White



New York Grey



Metropolis Black

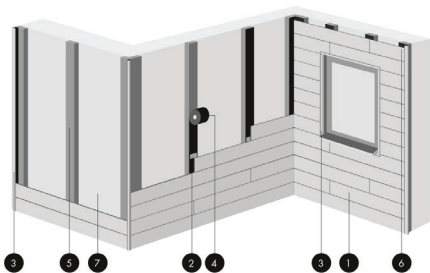

1. PURA[®] NFC siding
2. PURA[®] NFC clip
3. Colour-matched profile
4. EPDM
5. Subframe
6. Colour-matched fasteners
7. Load-bearing wall
8. Ventilation airflow

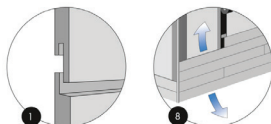

Engineered to be lightweight, long-lasting, and easy to cut and install. Siding is prefinished, doesn't require sealing, and has matching accessories.



Trespa's Electron Beam Curing makes it hard for dirt to build up and keeps the colors vibrant. High impact durability and resistance make it safe for daily wear and tear.



The Pura[®] NFC system is engineered to stay pristine; whether it's subjected to salty sea air, wind, rain humidity, or intense sunlight.

Cladding is only the beginning.

The thin brick products listed here are also sold through Acme Brick Company's nationwide network of company-owned sales offices and independent distributors. They have been tested under ASTM C67 standard procedures and meet or exceed the ASTM C1088 specifications for thin veneer brick units made from clay or shale. Product availability and lead times may vary by location; to see contact information for a location near you, please scan the QR code on this page or visit brick.com/where-buy.



King Klinker • Metro Brick • Royal Thin Brick • Fusion • English Cottage • CityScape • Old Carolina

King Klinker



Royal Thin Brick



English Cottage



CityScape



Old Carolina



Fusion





INNOVATIVE BUILDING PRODUCTS™
an **ACME BRICK** company

Brick is only the beginning.

When our company was founded in 1891, it was customary for homes and buildings to be clad in a single type of material. In our original market, likely as not that material was Acme Brick. Today, however, it is common to see buildings with as many as five different types of cladding. So as always, Acme Brick is listening to the changing needs and preferences of our customers.

In our reconfigured Innovative Building Products division, we have brought together many of the world's most innovative cladding solutions:

- **Thin brick** – many different lines including our own thinBRIK series: CityScape, Fusion, and English Cottage
- **Natural stone** – including Acme's exclusive Stonebrook line and the CUPACLAD slate wall system
- Premier **metal panels** from MAC Metal Architectural
- **Ceramic and terracotta cladding systems** like Agrob Buchtal
- Advanced **high-pressure laminate panels**, such as Pura NFC by Trespa
- **Panel-based fastening systems**, including our patented Fast Track System

As our product offerings have expanded, so has our service. A support team based at our Fort Worth headquarters stands ready to help with design tips, shop drawings, and comprehensive technical assistance for every Acme and IBP product.

Even as our product offerings expand, our mission remains the same: to fire the imaginations of architects, and to furnish the materials they need to execute their boldest designs.

